

機種 Items	A	B1	B2	C	D	E	F	J	K	L
FA-90R3	64	20	38	129	∅168	67	60	∅4.3	M7×1	M9×0.75
FA-120R3	64	20	38	129	∅168	67	60	∅4.3	M7×1	M9×0.75
FA-170R3	94	25	50	156	∅198	85	76	∅4.5	M8×1.25	M10×1
FA-200R3	94	25	50	155	∅198	85	75	∅4.5	M8×1.25	M10×1
FA-325R5	100	30	49	170	∅220	92	77	∅5.2	M8×1.25	M12×1
FA-450R3	110	30	49	200	∅250	92	100	∅5.2	M10×1.25	M14×1
FG-84R3	70	40	40	170	∅250	100	100	∅5.2	M10×1.25	M14×1

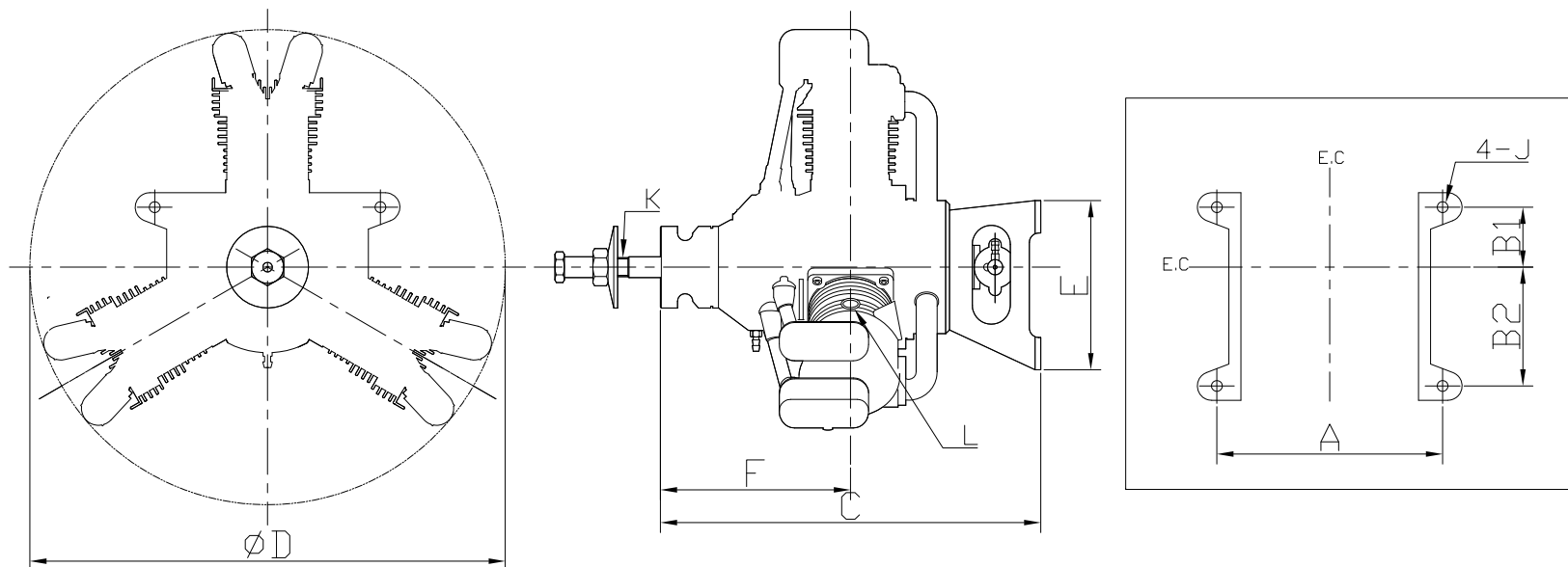

機種 Items	シリンダ/ピストン Cylinder/ Piston	行程容積 Disp (cc)	ボア Bore (mm)	ストローク Stroke (mm)	実用回転数 Practical Range (r.p.m.)	地上最高回転数 Ground Max-Range (r.p.m.)	重量 Weight (g)	燃費 Fuel efficiency (cc/min)	ブレークイン・プロペラ Break-in Prop. (in.)
FA-90R3	A.A.C	15.08	20.0×3	16.0×3	2,000~10,000	8,500~9,500	850	25	13"×6"
FA-120R3	A.A.C	19.15	22.4×3	16.2×3	1,800~10,000	8,800~9,500	890	25	13"×8"
FA-170R3	A.A.C	27.82	24.8×3	19.2×3	2,000~9,500	8,000~9,000	1,355	45	15"×8"
FA-200R3	A.A.C	32.98	27.0×3	19.2×3	1,800~9500	8,000~9,000	1,360	46	16"×8"
FA-325R5	A.A.C	53.14	24.8×5	22.0×5	1,700~7500	6,000~7,000	2,410	75	20"×8"
FA-450R3	A.A.C	75.18	34.0×3	27.6×3	1,200~8,000	6,000~7,500	2,950	100	22"×10"
FG-84R3	A.A.C	84.28	36.0×3	27.6×3	1,300~7,000	5,500~6,500	3,057	40	24"×10"